

Small Venues (less than 1,000 seats)

	<i>Stage Left</i>	<i>Stage Right</i>	<i>Typical Venue</i>
Very-Small Venue with Wide Coverage Angle			Small club or theatre

Full-range cabinets:	4 (Xn)
MB/HF cabinets:	none
LF cabinets:	2 (Xb)
Subwoofer cabinets:	2 (Xds)
Horizontal coverage:	95 to 120 degrees
Pattern:	symmetrical
Amplifier channels:	2 x 5 channels
Total Power:	2 x 5,200 W

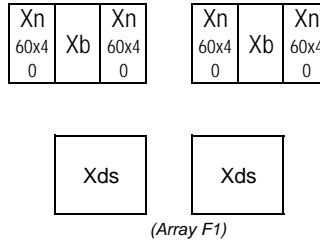

Small Venue with Narrow Coverage Angle			Small club or theatre
---	--	--	------------------------------

Full-range cabinets:	4 (Xn)
MB/HF cabinets:	4 (Xf)
LF cabinets:	4 (Xb)
Subwoofer cabinets:	4 (Xds)
Horizontal coverage:	60 to 80 degrees
Pattern:	symmetrical
Amplifier channels:	2 x 9 channels
Total Power:	2 x 10,000 W

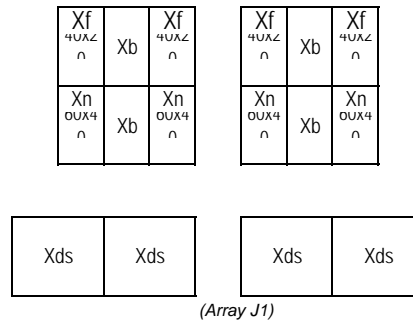

Small Venue with Wide Coverage Angle			Small club or theatre
---	--	--	------------------------------

Full-range cabinets:	8 (Xcn)
MB/HF cabinets:	none
LF cabinets:	4 (Xcb)
Subwoofer cabinets:	2 (Xds)
Horizontal coverage:	95 to 120 degrees
Pattern:	symmetrical
Amplifier channels:	2 x 6 channels
Total Power:	2 x 8,000 W

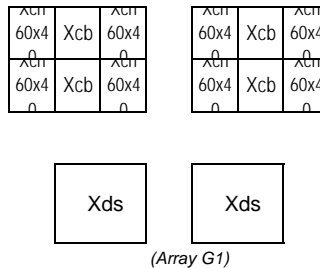

Small Venue with Wide Coverage Angle			Theatre
---	--	--	----------------

Full-range cabinets:	8 (Xn)
MB/HF cabinets:	none
LF cabinets:	4 (Xb)
Subwoofer cabinets:	2 (Xds)
Horizontal coverage:	95 to 120 degrees
Pattern:	symmetrical
Amplifier channels:	2 x 9 channels
Total Power:	2 x 9,200 W

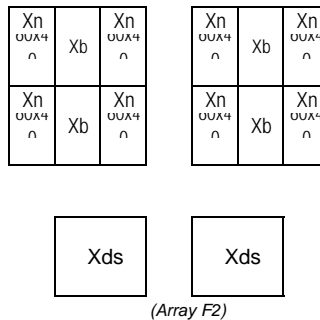

Medium Venues (1,000 to 5,000 seats)

Medium Venue with Narrow Coverage Angle

Small Ampitheater

Full-range cabinets:	4 (Xcn)
MB/HF cabinets:	8 (Xf)
LF cabinets:	8 (Xb)
Subwoofer cabinets:	4 (Xds)
Horizontal coverage:	60 to 80 degrees
Pattern:	symmetrical
Amplifier channels:	2 x 13 channels
Total Power:	2 x 14,800 W

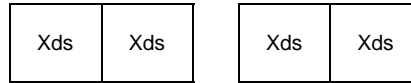
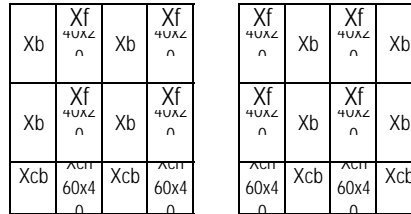

(Array A1)

Medium Venue with Narrow Coverage Angle

Large Theatre

Full-range cabinets:	4 (Xn)
MB/HF cabinets:	8 (Xf)
LF cabinets:	6 (Xb)
Subwoofer cabinets:	4 (Xds)
Horizontal coverage:	60 to 80 degrees
Pattern:	symmetrical
Amplifier channels:	2 x 12 channels
Total Power:	2 x 13,600 W

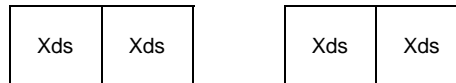
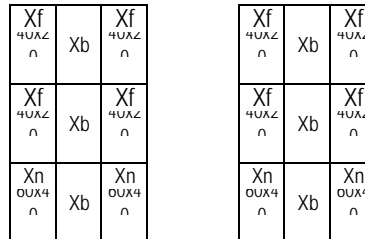

(Array J2)

Medium Venue with Wide Coverage Angle

Small Ampitheater

Full-range cabinets:	6 (Xcn)
MB/HF cabinets:	12 (Xf)
LF cabinets:	8 (Xb), 4 (Xcb)
Subwoofer cabinets:	6 (Xds)
Horizontal coverage:	90 to 120 degrees
Pattern:	symmetrical
Amplifier channels:	2x 20 channels
Total Power:	2x 20,400 W

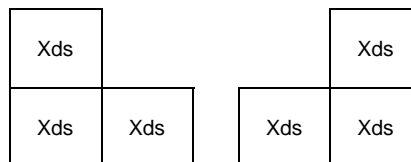
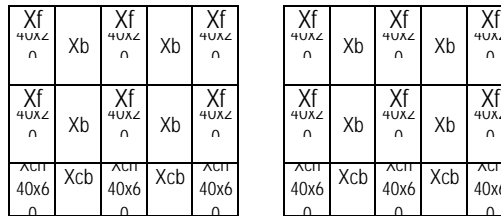

(Array B1)

Large Venues (greater than 5,000 seats)

Large Venue with Narrow Coverage Angle

Large Ampitheater

Full-range cabinets:	4 (Xcn)
MB/HF cabinets:	16 (Xf)
LF cabinets	16 (Xb)
Subwoofer cabinets	8 (Xds)
Horizontal coverage:	60 to 80 degrees
Pattern:	symmetrical
Amplifier channels:	2 x 21 channels
Total Power:	2 x 26,800 W

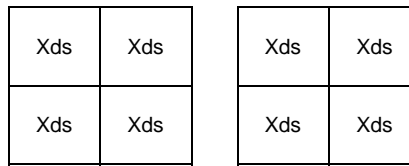
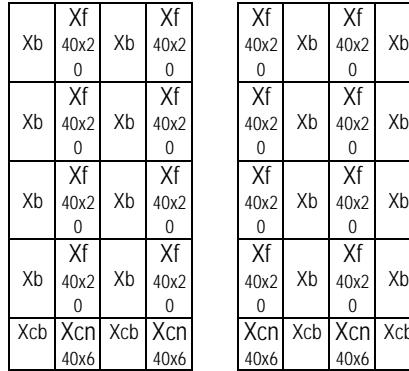

(Array A2)

Large Venue with Medium Coverage Angle

Large Ampitheater

Full-range cabinets:	6 (Xcn)
MB/HF cabinets:	24 (Xf)
LF cabinets	16 (Xb)
Subwoofer cabinets	10 (Xds)
Horizontal coverage:	90 to 120 degrees
Pattern:	symmetrical
Amplifier channels:	2 x 32 channels
Total Power:	2 x 34,800 W

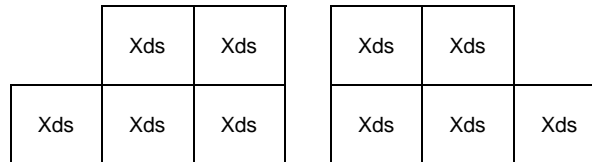
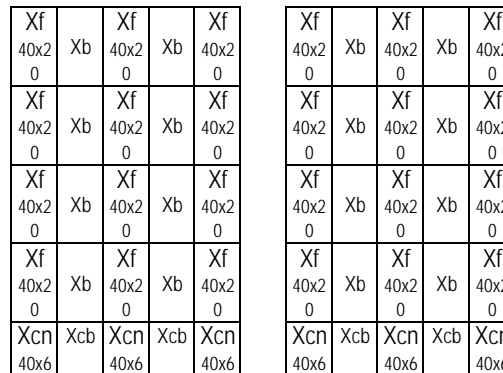

(Array B2)

Large Venues (greater than 5,000 seats)

Large Venue with Wide Coverage Angle

Small Arena

Full-range cabinets:	10 (Xcn)
MB/HF cabinets:	8 (Xf)
LF cabinets:	8 (Xb) and 4 (Xcb)
Subwoofer cabinets:	6 (Xds)
Horizontal coverage:	105 to 140 degrees
Pattern:	symmetrical
Amplifier channels:	2 x 16 channels
Total Power:	2 x 18,000 W

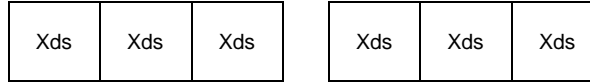
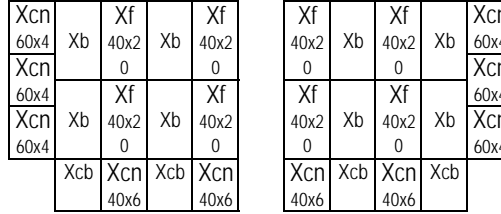

(Array C1)

Large Venue with Very-Wide Coverage Angle

Small Arena

Full-range cabinets:	12 (Xcn)
MB/HF cabinets:	12 (Xf)
LF cabinets:	12 (Xb) and 4 (Xcb)
Subwoofer cabinets:	8 (Xds)
Horizontal coverage:	135 to 180 degrees
Pattern:	Asymmetrical
Amplifier channels:	2 x 24 channels
Total Power:	2 x 26,000 W

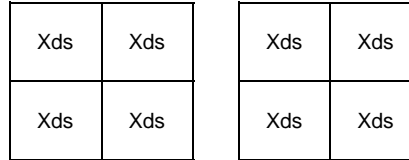
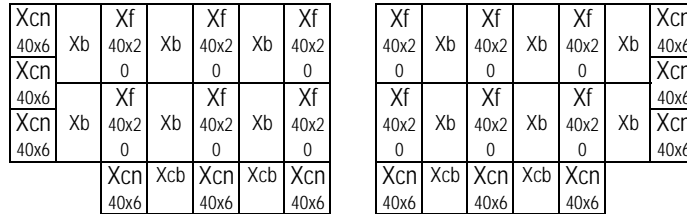

(Array D1)

Large Venue with Wide Coverage Angles

Large Arena

Full-range cabinets:	6 (Xn) and 4 (Xcn)
MB/HF cabinets:	16 (Xf)
LF cabinets:	16 (Xb) and 4 (Xcb)
Subwoofer cabinets:	10 (Xds)
Horizontal coverage:	105 to 140 degrees
Pattern:	Asymmetrical
Amplifier channels:	2 x 28 channels
Total Power:	2 x 32,000 W

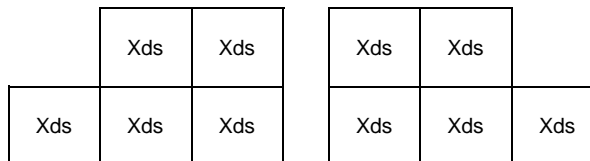
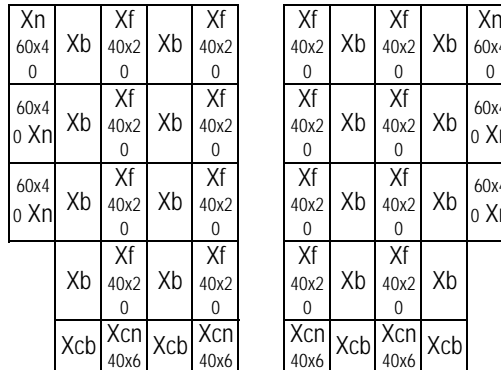

(Array C2)

Large Venues (greater than 5,000 seats)

Large Venue with Very-Wide Coverage Angle	Large Arena
--	--------------------

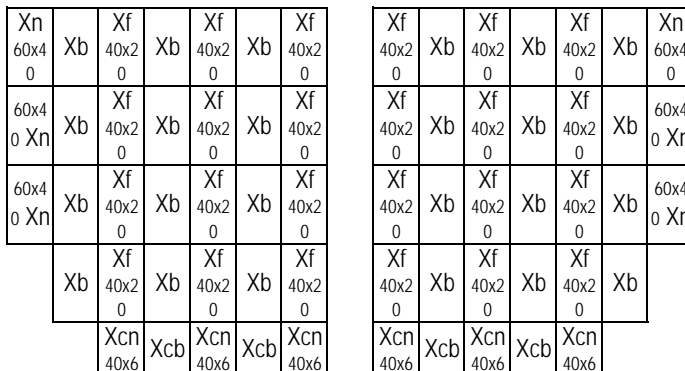

Full-range cabinets:	6 (Xn) and 6 (Xcn)
MB/HF cabinets:	24 (Xf)
LF cabinets:	24 (Xb) and 4 (Xcb)
Subwoofer cabinets:	12 (Xds)
Horizontal coverage:	135 to 180 degrees
Pattern:	Asymmetrical
Amplifier channels:	2 x 39 channels
Total Power:	2 x 44,000 W

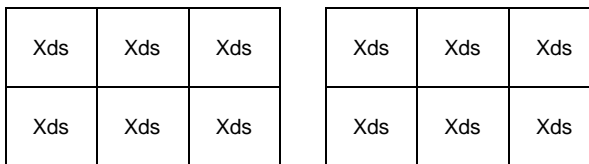

(Array D2)

Large Venue with Very-Wide Angles and Wrap-Around Seating	Large Arena
--	--------------------

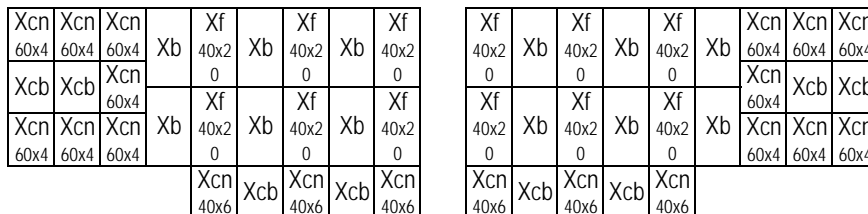

Full-range cabinets:	20 (Xcn)
MB/HF cabinets:	12 (Xf)
LF cabinets:	12 (Xb) and 8 (Xcb)
Subwoofer cabinets:	12 (Xds)
Horizontal coverage:	135 to 180 degrees
Pattern:	Asymmetrical
Amplifier channels:	2 x 26 channels
Total Power:	2 x 28,800 W

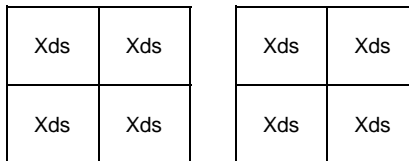

(Array E1)

Large Venues (greater than 5,000 seats)

Very-Large Venue with Very-Wide Angles and Wrap-Around Seating Large Arena

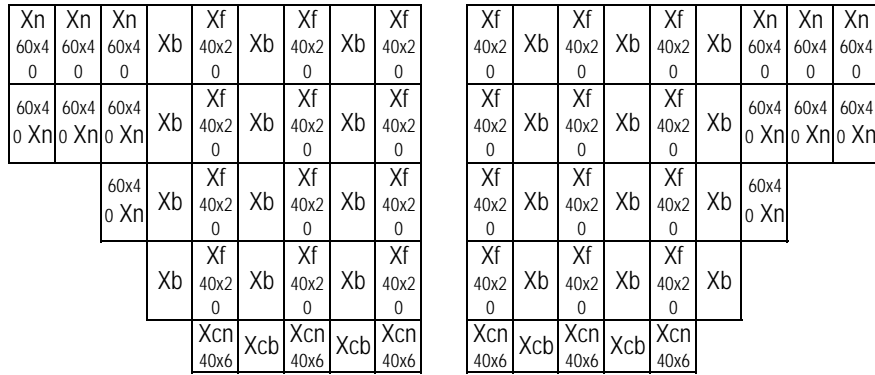

Full-range cabinets: 14 (Xn) and 6 (Xcn)
 MB/HF cabinets: 24 (Xf)
 LF cabinets: 24 (Xb) and 4 (Xcb)
 Subwoofer cabinets: 12 (Xds)
 Horizontal coverage: 135 to 180 degrees
 Pattern: Asymmetrical
 Amplifier channels: 2 x 43 channels
 Total Power: 2 x 48,800 W

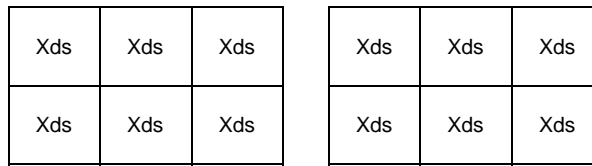

(Array E2)

Central Cluster Arrays

Small Venue, Very-Wide Coverage

Full-range cabinets:	6 (Xcn)
MB/HF cabinets:	none
LF cabinets	4 (Xcb)
Subwoofer cabinets	2 (Xds)
Horizontal coverage:	130 to 180 degrees
Pattern:	Symmetrical
Amplifier channels:	12 channels
Total Power:	12,400 W

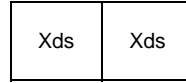
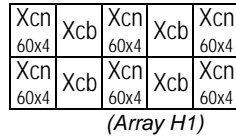

Small Venue, Very-Wide Coverage

Full-range cabinets:	6 (Xn)
MB/HF cabinets:	none
LF cabinets	4 (Xb)
Subwoofer cabinets	2 (Xds)
Horizontal coverage:	130 to 180 degrees
Pattern:	Symmetrical
Amplifier channels:	17 channels
Total Power:	16,400 W

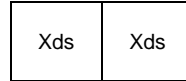
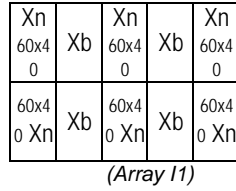

Other Central Cluster Arrays

The following arrays are recommended for the central-cluster applications:

Application	Recommended Array
very-small venue, wide coverage angle	F1
small venue, narrow coverage angle	J1
small venue, wide coverage angle	F2
small venue, wide coverage angle	G1
small venue, very-wide coverage angle	H1
small venue, very-wide coverage angle	I1
medium venue, narrow coverage angle	J2
medium venue, medium coverage angle	B1
large venue, medium coverage angle	B2

Please refer to the previous sections for illustrations of the arrays.
 For central cluster applications, only one channel of the illustrated stereo-pair array.