



Electro-Voice®
a MARK IV company

Model 602TR Dynamic Microphone

SPECIFICATIONS

Type:

Transistorized dynamic

Frequency Response:

100 to 5,000 Hz

Impedance:

Matches 100 to 500 ohm carbon input

Polar Pattern:

Pressure gradient
(differential close-talking)

Output Level:

-48 dB at 1/4-inch from front of the microphone with normal speech,
(0 dB = 1 volt/dyne/cm²)

Case Material:

High impact phenolic

Finish:

Black

Transistor Amplifier,

Power Gain:

35 dB (16 volts)

Current Drain:

16 mA (16.8 volts),
38 mA (28 volts)

Rated Supply Voltage:

12 to 28 volts,
usable down to 2 volts

Maximum Undistorted Output:

1.0 volt (16.8 volt supply),
2.0 volts (28 volt supply)

Dimensions:

60.3 mm (2.38 in.) wide
100 mm (3.94 in.) high
50.8 mm (2 in.) deep

Net Weight:

369 g (13 ounces)

Cable:

4-conductor, coiled cord
1.52 m (5 ft) extended

Switch:

Wiping contact leaf switch opens microphone circuit in off position, also provided with contacts for relay operation.

Accessory Supplied:

Panel mounting bracket

Temperature Range:

-17.8 C (0° F) to
60 C (140° F)

FAA Approval:

TC 3R42-1

DESCRIPTION AND APPLICATIONS

The Electro-Voice Model 602TR is a hand-held dynamic microphone, designed for high articulation speech transmission under high ambient noise. The 602TR is the result of continuous study of the needs of the communications industry and it uniquely meets the specialized requirements of airline, two-way radio and industrial applications. The 602TR is a transistorized pressure-gradient microphone utilizing two sound entrances for reduction of interfering ambient noise.

The 602TR comes in three versions. They are as follows:

- 602-4182 No Gain Control,
XLR-4-12C Connector or
equivalent
- 602-4183 No Gain Control,
PJ-068 Connector
- 602-3225 Gain Control,
PJ-068 Connector

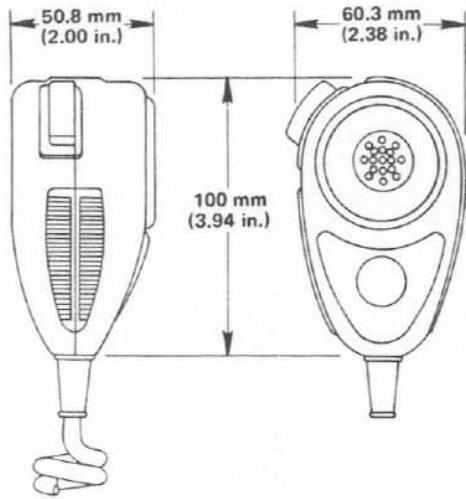

FIGURE 1 - Dimensions

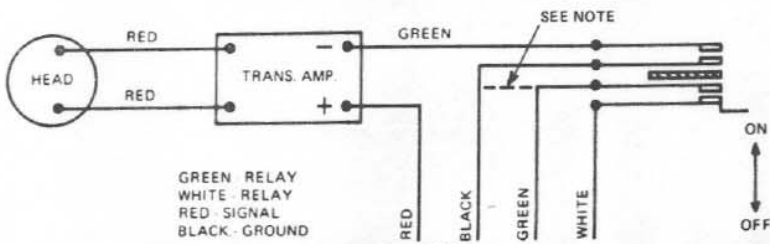

FIGURE 2 - 602TR Wiring Diagram

NOTE: JUMPER USED ON - 3225 and - 4183
GREEN WIRE NOT USED

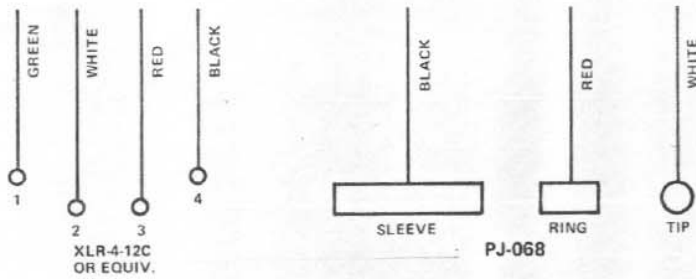

FIGURE 3 - Connections

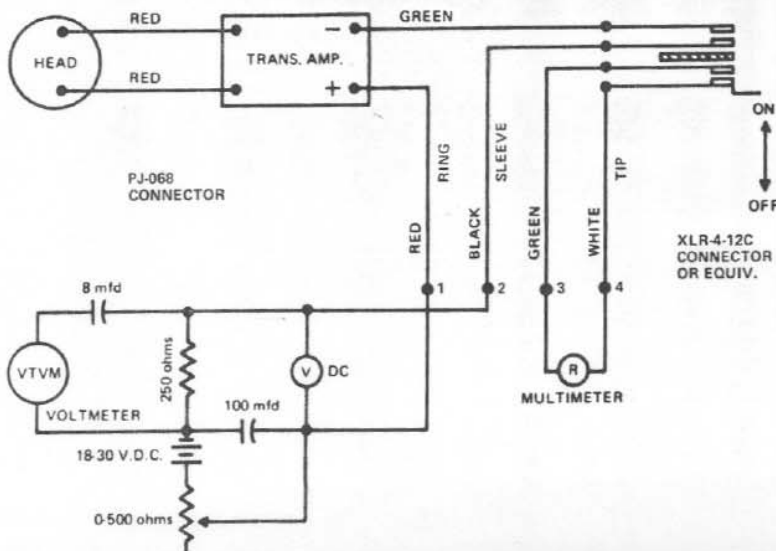
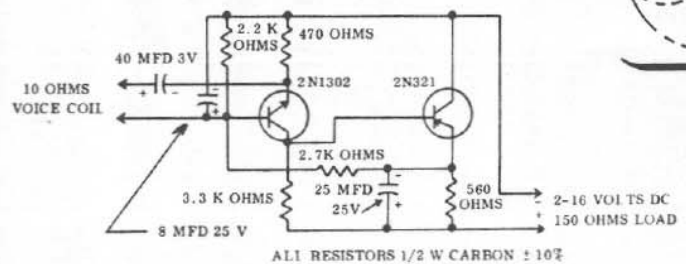
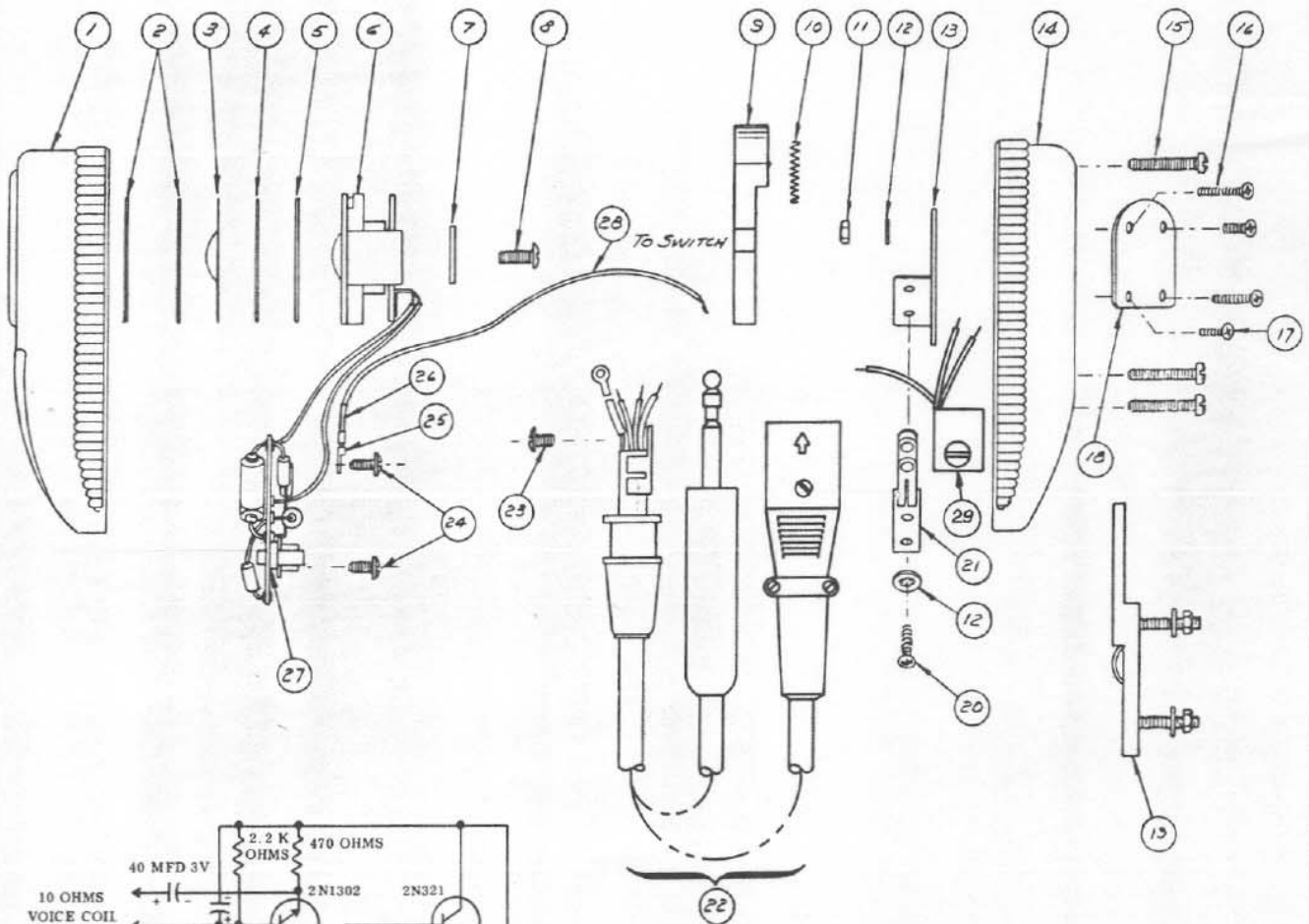

FIGURE 4 - Test Set-up

REPLACEMENT PARTS FOR 602TR

Item	Part No.	Description	Req'd	Item	Part No.	Description	Req'd
1	D2400	Case front	1	16	C60028-AD	Screw (2-56 x 7/16)	2
2	74767	Grille Cloth	2	17	C60024-AD	Screw (2-56 x 1/4)	2
3	7605	Shield, magnetic	1	18	48049	Nameplate	1
4	3898	Washer, rubber	1	19	8474	Dash mounting bracket	1
5	3863	Washer, paper	1	20	B60029-AD	Screw (2-56 x 9/16) switch	2
6	C8009	Head subassembly	1	21	56011	Switch	1
7	2341	Head holder bar	1	22	K8111	Cable S/A XLR-4-12C conn. or equivalent	1
8	E60516	Screw (6-32 x 3/8)	2	22	V8072	Cable S/A PJ-068 conn.	1
9	75318-LF	Button, switch	1	22	89090XX	Cable S/A no connector	1
10	19016	Spring, switch	1	23	E60513-AD	Screw (6-32 x 3/16)	1
11	2020-AD	Nut, hex (2-56)	1	24	E60314-AD	Screw (4-40 x 1/4)	2
12	3836-AD	Lock washer (switch)	3	25	2722	Solder, lug	1
13	73353	Bracket, switch	1	26	A6602	Tube, cloth	1
14	D2401	Case back	1	27	8655	Transistor amplifier S/A	1
14	F2401	Case back w/adj. hole	1	28	1608-09	Leadwire, black, 4" long	3
15	A605210	Screw (6-32 x 5/8)	3	29	46192	Gain control (602-3225)	1



SCHEMATIC - TRANSISTOR AMPLIFIER

FIGURE 5 - Model 602TR Assembly

OVERHAUL INSTRUCTIONS

1. **Special Tools.** None.
2. **Disassembly.** (See Figure 5)
 - a. Begin disassembly by removing the three screws holding the case back.
 - b. Do not remove the head sub-assembly unless it is necessary to replace the head. If it is necessary to replace this component, proceed as indicated in steps c and d.
 - c. Remove two screws from bar holding head assembly in place. Gently remove the head.
 - d. With the head assembly removed, it is possible to unsolder all leads and replace the head.
 - e. The switch assembly should be disassembled carefully.
 - f. Do not unsolder leads to switch unless necessary for replacement of cable.
3. **Cleaning:**
 - a. Thoroughly clean all dust and dirt from microphone by first using dry, compressed air to dislodge dirt from inaccessible corners. Then clean each part with a lint-free cloth or brush, slightly dampened with dry-cleaning solvent, Federal Specification P-S-661. **Do not get solvent on head diaphragm.**
 - b. Remove pits from switch contacts by burnishing.
4. **Inspection:**
 - a. Inspect switch contacts for signs of excessive wear.
 - b. Examine unit for damaged or dried-out-wiring or sleeving. Check all soldering connections for good contacts.
 - c. Check cable for signs of damage such as cuts or cracks.
5. **Repair or Replacement:**
 - a. Replace any part which is damaged.
 - b. Check resistance across the head with an ohmmeter. It should read about 10 ohms. In

addition, a distinct click from the microphone element should be heard when the circuit to the ohmmeter is made or interrupted. If it is not, replace head as described in the reassembly procedure.

6. **Lubrication:**
 - a. Clean and add small drop of light machine oil to each end of switch actuator spring.
7. **Reassembly:**
 - a. Reassembly is the reverse of disassembly.
8. **Test Procedure** (See Figure 4)
9. **Check of Switch Operation:**
 - a. With the switch released, check the resistance between the white and green leads. It should be infinite.
 - b. Check the resistance between the red and black leads. It should be infinite.
 - c. Depress switch and check resistance between white and green leads. It should be zero.
 - d. Depress switch and check resistance between red and black leads. It should be from 1000 to 10,000 ohms depending on meter polarity.
10. **Check of Microphone Output:**

The best procedure for testing the microphone is to compare its output with one known to be operating properly, using the test set-up shown in Figure 4. Check the output voltage as follows:

 - a. Depress microphone switch and adjust test voltage to obtain 12 to 14 volts on DC meter.
 - b. Hold the test microphone about one-quarter inch from the mouth and talk at normal speech level with microphone switch depressed. An output of about 0.31 volt should be obtained.

WARRANTY (Limited) —

Electro-Voice aircraft microphones and accessories are guaranteed for 18 months from date of original purchase against malfunction due to defects in workmanship and materials. If such malfunction occurs, microphone will be repaired or replaced (at our option) without charge for materials or labor if delivered prepaid to the proper Electro-Voice service facility. Unit will be returned prepaid. Warranty does not cover finish, appearance items, cables, cable connectors, or switches and does not cover malfunction due to abuse or operation at other than specified conditions. Repair by other than Electro-Voice or its authorized service agencies will void this guarantee.

For correct shipping address, instructions on return of Electro-Voice products for repair, and locations of authorized service agencies, please write: Service Department, Electro-Voice, Inc., 600 Cecil Street, Buchanan, Michigan 49107 (Phone 616/695-6831).

Electro-Voice also maintains complete facilities for non-warranty service of E-V products.

Specifications subject to change without notice.



ELECTRO-VOICE, INC., 600 Cecil Street, Buchanan, Michigan 49107

MANUFACTURING PLANTS AT ■ BUCHANAN, MI ■ NEWPORT, TN ■ SEVIERVILLE, TN ■ OKLAHOMA CITY, OK ■ GANANOQUE, ONT.
©Electro-Voice Inc. 1991 ■ Litho in U.S.A. Part Number 53988-046

— a MARK IV company —