



N/D168

N/DYM® Dynamic Snare Drum Microphone

- Designed specifically for snare drums
- Tailored frequency response
- Small profile for easy, out-of-the-way placement
- Includes complete "three-point-swivel" clip-on rim mounting system
- Steel construction for rugged durability
- Cardioid polar pattern for optimized acoustic isolation

Description

The Electro-Voice N/D168 is designed with a tailored frequency response, enhancing the sound of snare drums in both professional live performance or studio instrument recording. The N/D168 is housed in a durable, compact steel case with a Memraflex™ grille screen. Accessories include a soft zippered "gig" bag and an EV 84543 three-point swivel clamping system for attachment to a snare drum or stand. This clamp firmly holds the microphone in place while allowing positioning freedom, eliminating the fear of damaging the drum hoop.

The unique snare "sound" is an individual preference that is usually achieved by selecting the right microphone and its placement. But there are few places a microphone can be mounted on or near the drum that will not interfere with the drummer. This problem makes snare drums somewhat difficult to mic. To address this concern, the compact size of the N/D168 and the clamp-on mounting system allows mic placement on or near the drum to reproduce the wanted sound characteristics and still not obstruct the drummer. The clamping system is designed to attach the N/D168 to the hoop or "rim" of the snare drum, mounting hardware or a

mic stand. The internal shock mount mechanically isolates the transducer from impacts on the microphone case and drum vibrations.

Operation

The N/D168's cardioid pickup pattern is least sensitive to sound coming towards the rear of the microphone. Therefore, to reduce high-hat or stage monitor "bleed through" into the snare mic, position the N/D168 with the high-hat or monitor approximately 150° to 180° from the front of the mic. In general, the character of the "miked sound" may be adjusted by changing either the distance of the mic from the drumhead, the angle between the drumhead and the mic or the area on the drumhead the mic is pointed toward. A good starting point is to position the mic at a 45° angle about 1½ inches from the drum head's surface. From this position, adjustments may be made until the desired sound is achieved.

Certified Performance

Every N/D168 is inspected by a quality control tester and subjected to a computer-controlled test system that verifies numerous performance parameters. After the performance meets or exceeds our rigorous stan-

dards, the actual measured frequency response is plotted on a "Certificate of Performance" and included with the microphone. Certified performance may vary from published "Average Response." This certificate guarantees that each N/D168 will perform to exacting standards of the **100% quality assurance testing**, established by EV's design engineers.

Limited Warranty

Electro-Voice products are guaranteed against malfunction due to defects in materials or workmanship for a specified period, as noted in the individual product-line statement(s) below, or in the individual product data sheet or owner's manual, beginning with the date of original purchase. If such malfunction occurs during the specified period, the product will be repaired or replaced (at our option) without charge. The product will be returned to the customer prepaid. **Exclusions and Limitations:** The Limited Warranty does not apply to: (a) exterior finish or appearance; (b) certain specific items described in the individual product-line statement(s) below, or in the individual product data sheet or owner's manual; (c) malfunction resulting from use or operation of the product other than as specified in the

N/D 168 Cardioid Snare Drum Microphone

N/D 168 Cardioid Snare Drum Microphone

product data sheet or owner's manual; (d) malfunction resulting from misuse or abuse of the product; or (e) malfunction occurring at any time after repairs have been made to the product by anyone other than EVI Audio Service or any of its authorized service representatives. **Obtaining Warranty Service:** To obtain warranty service, a customer must deliver the product, prepaid, to EVI Audio Service or any of its authorized service representatives together with proof of purchase of the product in the form of a bill of sale or receipted invoice. A list of authorized service representatives is available from EVI Audio Service at 600 Cecil Street, Buchanan, MI 49107 (800/685-2606 or FAX 616/695-4743). **Incidental and Consequential Damages Excluded:** Product repair or replacement and return to the customer are the only remedies provided to the customer. Electro-Voice shall

not be liable for any incidental or consequential damages including, without limitation, injury to persons or property or loss of use. Some states do not allow the exclusion or limitation of incidental or consequential damages so the above limitation or exclusion may not apply to you. **Other Rights:** This warranty gives you specific legal rights, and you may also have other rights which vary from state to state.

Electro-Voice Wired Microphones are guaranteed against malfunction from any cause for two (2) years from the date of original purchase. In addition, the Limited Warranty for the acoustic system contained in these microphones shall apply for the life of the product, defined as a period of ten (10) years from the date that the manufacture of the specific microphone has been discontinued. Any and all active electronics incorporated in these microphones are guaranteed

against malfunction due to defects in materials or workmanship for a period of three (3) years from the date of original purchase. The Limited Warranty does not extend to cables, cable connectors, or switches. Additional details are included in the Uniform Limited Warranty statement.

For technical assistance, contact Technical Support at 800/234-6831 or 616/695-6831, M-F, 8:00 a.m. to 5:00 p.m. Eastern Standard time.

Specifications subject to change without notice.

Figure 1—Frequency Response

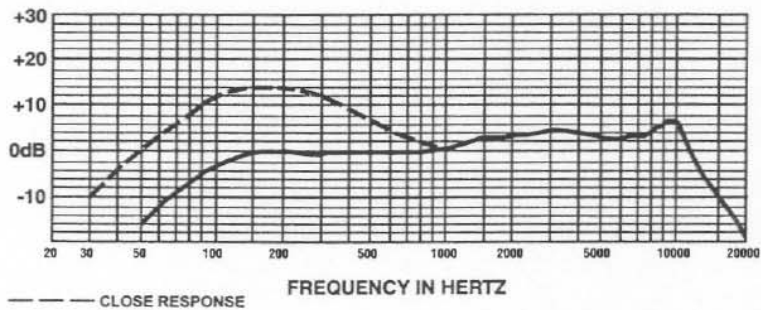
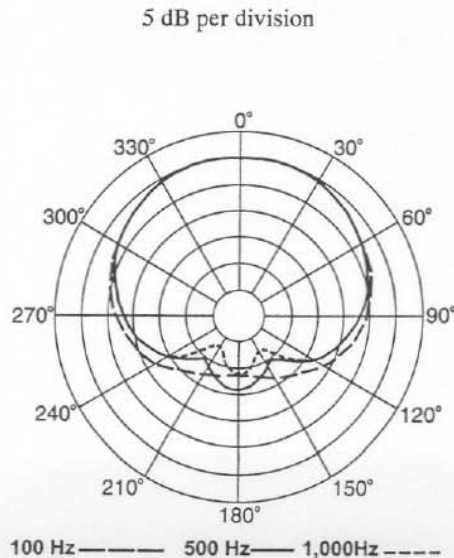
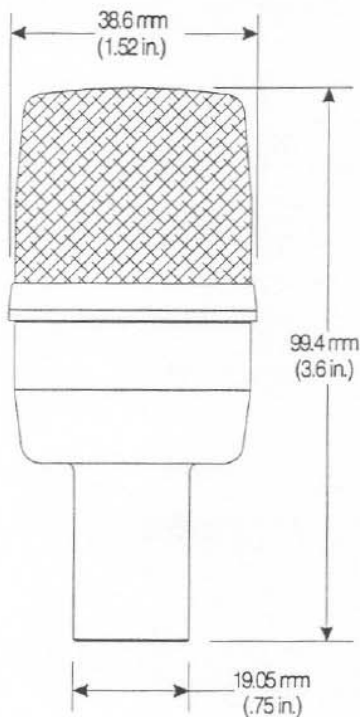

Figure 2—Polar Response



N/D 168 Cardioid Snare Drum Microphone

Figure 3—Dimensions



N/D 168 Cardioid Snare Drum Microphone

Figure 4—Clamping System Diagram

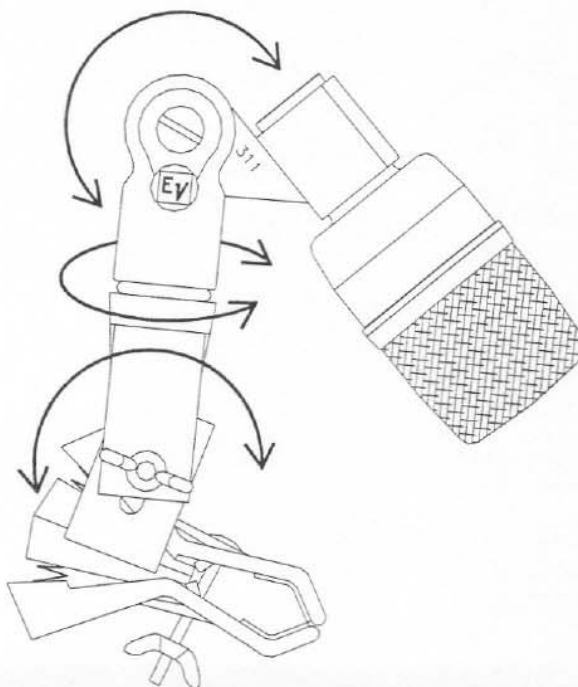

N/D 168 Cardioid Snare Drum Microphone

Specifications

Frequency Response,

Close Response:

25-15,000 Hz

Far Response:

70-15,000 Hz

Polar Pattern:

Cardioid

Sensitivity,

Open Circuit Voltage @ 1 kHz:

2.4 mV/pascal

Power level @ 1 kHz:

-53 dB

(0 dB = 1mW/pascal)

Dynamic Range:

141 dB

Equivalent Output Noise:

16 dB A weighted

(0 dB = 0.00002 pascal)

Impedance:

300 ohms balanced (low-Z)

Materials,

Grille Screen:

Memraflex™

Case:

Steel

Finish:

Nonreflecting black

Accessories Included:

Custom EV 84543 clamping system

Soft zippered "gig" bag

Dimensions,

Length:

91.4 mm (3.60 in.)

Diameter:

38.6 mm (1.52 in.)

Shank:

19 mm (0.75 in.)

Net Weight:

153 g (5.4 oz)

Shipping Weight:

440 g (16 oz)

Electro-Voice®

600 Cecil Street, Buchanan, MI 49107

616/695-6831, 616/695-1304 Fax

©EVI Audio 1997 • Litho in U.S.A.